

SPECIFICATION

STATIC DIMENSIONS

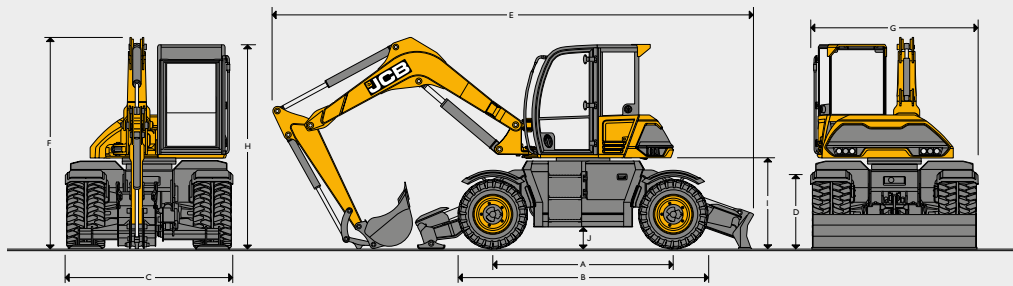

A	Wheelbase	mm	2650
B	Length over tyres	mm	3689
C	Width over tyres	mm	2420
D	Height over tyres	mm	1016
G	Transport width	mm	2440
H	Height over cab	mm	2988
I	Clearance under counterweight	mm	1319
J	Ground clearance	mm	298

TAB

Dipper lengths		1.65m	2.0m	2.25m
E	Roading length	mm	5899	5899
E	Transport length	mm	7654	7730
F	Roading height	mm	3907	3907
F	Transport height	mm	2988	2988

Monoboam

Dipper lengths		1.65m	2.0m	2.25m
E	Roading length	mm	6406	6406
E	Transport length	mm	7050	6944
F	Roading height	mm	3973	3973
F	Transport height	mm	3132	3437

*Machine is specified with a rear dozer blade. Please check chassis options for alternative specification dimensions.

CHASSIS OPTIONS

Any combination of dozer (parallel/radial), stabiliser or grab stowage bar are available to both front and/or rear of chassis.

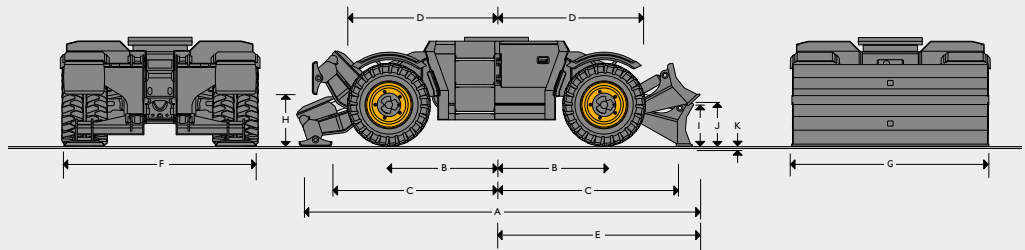

Front axle / rear axle	Oscillating steering axle / rigid steering axle		
Axles load capacity	14 tonnes		
Axles load oscillation	+/- 8 degrees		
Transmission	Hydrostatic drive via piston motor and stepless transmission		
A	Overall length		
	Rear stabiliser only	mm	4119
	Rear dozer only (raised)	mm	Parallel: 4342, Radial: 4319
	Front dozer and rear stabiliser (raised)	mm	Parallel: 4773, Radial: 4749
	Front and rear stabiliser (raised)	mm	4550
B	Centre of slew ring to front and rear axle	mm	1325
C	Centre of slew ring to front stabiliser (rear stabiliser)	mm	2275
D	Centre of slew ring to front tyre face	mm	1844
E	Centre of slew ring to rear dozer blade (lowered)	mm	Parallel: 2498, Radial: 2431
F	Width over stabilisers		2380
G	Width over dozer blade		2430
H	Stabiliser lift height		652
I	Dozer Lift height (clearance)		Parallel: 440, Radial: 501
J	Dozer Blade height (lowered)		505
K	Dozer Dig depth		Parallel: 160, Radial: 169

TURNING RADIUS		
	To outside of tyres	To outer edge of front mounted dozer blade
	4-Wheel Steer (mm)	4-Wheel Steer (mm)
Dual wheels	4163	4650
Single wheels	3946	4511
Floatation wheels	3946	4511

MAIN HYDRAULIC SYSTEM	
System	Electronically controlled system using two variable displacement piston pumps plus twin gear pumps for steering, brakes and cooling
Services pump	72cc variable displacement axial piston pump
Flow rate @ 2200rpm	158.4 l/min
Excavator main relief pressure	280 bar
Transmission pump – 40kph	85cc variable displacement axial piston pump in a closed loop hydrostatic drive system independent from working hydraulics
Flow rate @ 2200rpm	187 l/min
Transmission absolute pressure	525 bar
Transmission pump – 20kph	65cc variable displacement axial piston pump in a closed loop hydrostatic drive system independent from working hydraulics
Flow rate @ 2200rpm	143 l/min
Transmission absolute pressure	525 bar
High flow auxiliary	
High flow auxiliary pressure	210 bar
High flow auxiliary max. flow	120 l/min
Low flow auxiliary	
Low flow auxiliary pressure	210 bar
Low flow auxiliary max. flow	60 l/min
Second low flow auxiliary pressure	210 bar
Second low flow auxiliary max. flow	60 l/min
Hydraulic cylinders	Hardened, chromed piston rods with end damping on boom raise and dipper in
Filtration	
In tank	125 micron suction strainer
Main return line	10 micron return line filter

SERVICE CAPACITIES		
Fuel tank	litres	162
Engine coolant	litres	28
Engine oil	litres	14
Hydraulic system	litres	190
Hydraulic tank	litres	130
Transmission (dropbox)	litres	1.0
Axle differentials (each)	litres	Front = 18, rear = 14
Axle hubs (each)	litres	2.0

TYRES			
	Dual	Single	Floatation
Type	9.00x20 tyres with spacer ring	405/70 x 20 tyres	500/45 x22.5tyres
Inflation pressure	7.0 bar	4.0 bar	3.8 bar
Ply rating	14PR	16PR	16PR

ENGINE	
Model	JCB EcoMAX 444 TCA-99 Eu Stage IIIB, EPA Tier 4 Interim Compliant
Type	Water cooled, 4-stroke, 4-cylinder in-line, direct injection, turbocharged diesel
Rated power (ISO 14396)	81 kW (109 hp) @ 2200 rpm
Gross torque (ISO 14396)	516 Nm @ 1500 rpm
Piston displacement	4.4 litres
Air filtration	Dry element with secondary safety element and in-cab warning sensor
Starting system	12 volt
Batteries	12 volt
Alternator	12 volt, 150 ampere

SLEW SYSTEM	
Drive train	Axial piston type
Slew brake	Hydraulic braking plus automatic spring applied disc type parking brake
Slew torque	27.0 kNm
Slew speed	8.9 rpm
Slew gear	11 tooth pinion / 84 tooth ring

TRAVEL SPEED	
Max. roading speed	40 kp/h
Drawbar pull	45 kNm
Steering	Fully hydraulic system with 4-wheel steer, 2-wheel steer and crab steer

BRAKES	
Brakes	All hydraulic dual circuit brake system with positive brake back off
Parking brake	Built into the transmission
Gradability	26.6° / 50% maximum continuous

SPECIFICATION

OPERATING WEIGHTS

Machine equipped with no bucket, 75kg operator, 154kg fuel, dual tyres, 2000mm dipper.

		Monoboom	TAB
No dozer, no stabiliser	kg	10208	10487
Rear parallel dozer	kg	10750	11029
Rear radial dozer	kg	10695	10974
Rear stabiliser	kg	10636	10915
Front parallel dozer and rear stabiliser	kg	11178	11457
Front radial dozer and rear stabiliser	kg	11123	11402
Front stabiliser and rear stabiliser	kg	11064	11343

BUCKET AND ARM COMBINATIONS

Bucket options		GP Bucket								
		250	300	400	450	500	600	800	900	
Bucket width	mm	250	300	400	450	500	600	800	900	
Bucket capacity	m ³	0.06	0.08	0.11	0.13	0.15	0.19	0.27	0.31	
Bucket weight	kg	102	109	107	113	120	135	166	179	
Monoboom										
1.65m		☐	☐	☐	☐	☐	☐	☐	☐	
2.00m		☐	☐	☐	☐	☐	☐	☐	☐	
2.25m		☐	☐	☐	☐	☐	☐	☐	☐	
T.A.B.										
1.65m		☐	☐	☐	☐	☐	☐	☐	☐	
2.00m		☐	☐	☐	☐	☐	☐	☐	☐	
2.25m		☐	☐	☐	☐	☐	☐	☐	☐	

☐ = Material weight up to 2000kg/m³.

● = Material weight up to 1600kg/m³.

■ = Material weight up to 1200kg/m³.

The above are to subject to ground conditions and are a guide only.

WORKING RANGE – TAB

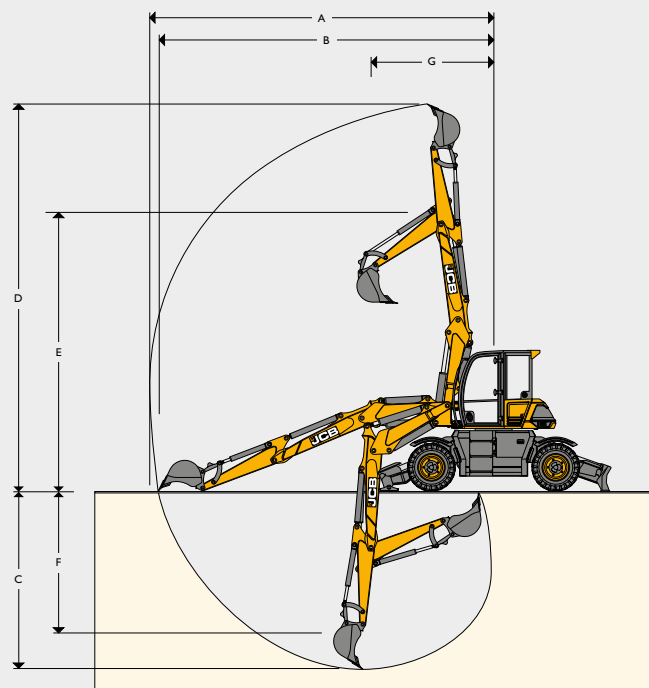

Dipper length		1.65m	2.0m	2.25m	
A	Max digging reach	mm	7420	7770	8020
B	Max digging reach (on ground)	mm	7165	7530	7785
C	Max digging depth	mm	3810	4160	4410
D	Max digging height	mm	8195	8545	8795
E	Max loadover height	mm	6380	6720	6965
F	Max vertical wall cut depth	mm	3000	3315	3540
G	Min swing radius	mm	2675	2920	3100
	Boom swing left	degrees	50		
	Boom swing right	degrees	70		
	Bucket rotation	degrees	184		
	Dipper tearout	kNm	48.3	42.3	39
	Bucket tearout	kNm	60.2		



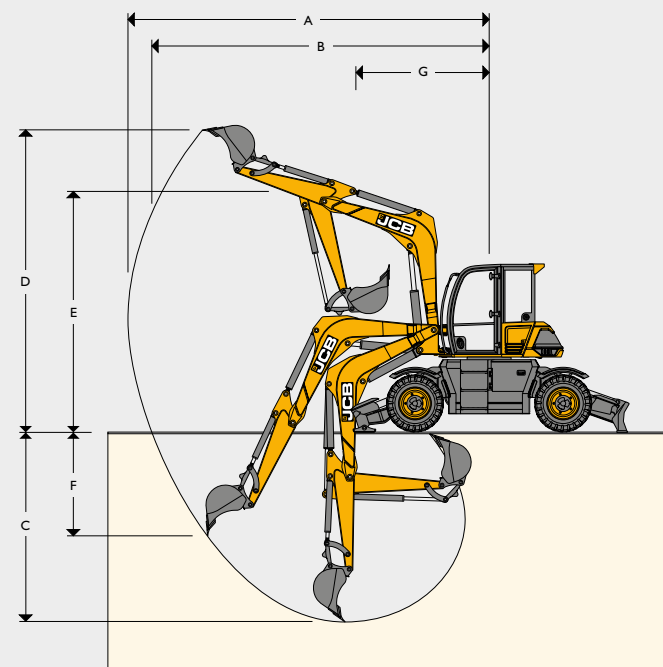





WORKING RANGE – MONOBOOM













Dipper length		1.65m	2.0m	2.25m	
A	Max digging reach	mm	6455	6785	7020
B	Max digging reach (on ground)	mm	6085	6445	6695
C	Max digging depth	mm	3370	3720	3970
D	Max digging height	mm	6445	6645	6790
E	Max loadover height	mm	4710	4915	5060
F	Max vertical wall cut depth	mm	1815	2135	2360
G	Min swing radius	mm	2645	2685	2715
	Boom swing left	degrees	50		
	Boom swing right	degrees	70		
	Bucket rotation	degrees	184		
	Dipper tearout	kNm	48.3	42.3	39
	Bucket tearout	kNm	60.2		

SPECIFICATION

LIFT CAPACITIES: 1.65M DIPPER WITH STABS AND DOZER DEPLOYED TAB

Reach	3m		4m		5m		6m		Capacity at Max Reach		
											
Load Point Ht.	kg	kg	kg	kg	kg	kg	kg	kg	kg	kg	mm
4.5m	1765*	1730*	2130*	2165*	1840*	1850*		1320	1690*	1290	5962
3.0m			2610*	2660*	2225*	1720	1690*	1300	1540*	1115	6515
1.5m			2975*	2215	2190*	1625	1720*	1250	1420*	1080	6633
0m			2750*	2170	2070*	1580	1535*	1240	1250*	1230*	6343
-1.0m	2860*	2725*	2305*	2200*	1735*	1660*			1060*	1020*	5892

LIFT CAPACITIES: 1.65M DIPPER OFF TYRES TAB

Reach	3m		4m		5m		6m		Capacity at Max Reach		
											
Load Point Ht.	kg	kg	kg	kg	kg	kg	kg	kg	kg	kg	mm
4.5m	1765*	1765*	2130*	2130*	1840*	1520			1690*	1100	5962
3.0m			2610*	2030	2225*	1455	1690*	1090	1540*	940	6515
1.5m			2975*	1850	2190*	1360	1720*	1050	1420*	900	6633
0m			2750*	1800	2070*	1320	1535*	1030	1250*	965	6343
-1.0m	2860*	2860*	2305*	1815	1735*	1330			1060*	1060*	5892











 Lift capacity front and rear.

 Lift capacity full circle.











Notes:

1. For lifting capacity including bucket, subtract total weight of bucket or bucket and quickhitch from above values.
2. Lifting capacities are based on ISO 10567, that is: 75% of minimum tipping load or 87% of hydraulic lift capacity, whichever is the less. Lifting capacities marked* are based on hydraulic capacity.
3. Lift capacities assume that the machine is on firm, level ground.
4. Lift capacities may be limited by local regulations. Please refer to your dealer.

LIFT CAPACITIES: 2.0M DIPPER OFF DOZER ONLY MONOBOOM

Reach	3m		4m		5m		6m		Capacity at Max Reach		mm
											
Load Point Ht.	kg	kg	kg	kg	kg	kg	kg	kg	kg	kg	mm
4.5m											
3.0m			1690*	1690*	1665*	1665*			1705*	1705*	5879
1.5m		3960*	2620*	2620*	2100*	2100*			1870*	1870*	5966
0m	5000*	5000*	3265*	3265*	2430*	2430*			2110*	2110*	5587
-1.0m	4995*	4995*	3305*	3305*					2315*	2315*	5014

LIFT CAPACITIES: 2.0M DIPPER OFF TYRES MONOBOOM

Reach	3m		4m		5m		6m		Capacity at Max Reach		mm
											
Load Point Ht.	kg	kg	kg	kg	kg	kg	kg	kg	kg	kg	mm
4.5m											
3.0m			1690*	1690*	1665*	1665*			1705*	1180	5845
1.5m		3060	2620*	2010	2100*	1440			1870*	1105	5978
0m	5000*	2850	3265*	1890	2430*	1375			2110*	1165	5648
-1.0m	4995*	2835	3305*	1850					2315*	1335	5121

 Lift capacity front and rear.

 Lift capacity full circle.

Notes:

1. For lifting capacity including bucket, subtract total weight of bucket or bucket and quickhitch from above values.
2. Lifting capacities are based on ISO 10567, that is: 75% of minimum tipping load or 87% of hydraulic lift capacity, whichever is the less. Lifting capacities marked* are based on hydraulic capacity.
3. Lift capacities assume that the machine is on firm, level ground.
4. Lift capacities may be limited by local regulations. Please refer to your dealer.