

Dimensions

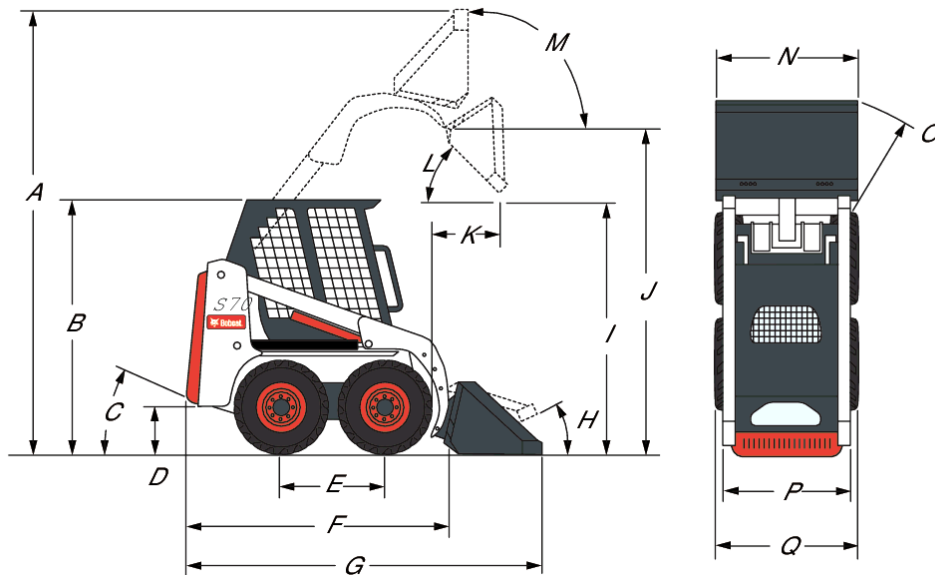

(A) Operating height	3051.0 mm
(B) Height with operator cab	1814.0 mm
(C) Angle of departure	25.0°
(D) Ground clearance	141.0 mm
(E) Wheelbase	722.0 mm
(F) Length without attachment	1925.0 mm
(G) Length with standard bucket	2472.0 mm
(H) Rollback at ground position	22.0°
(I) Dump height with standard bucket	1934.0 mm
(J) Height to bucket hinge pin	2399.0 mm
(K) Dump reach at maximum height	400.0 mm
(L) Dump angle at maximum height	34.0°
(M) Rollback fully raised at maximum height	97.0°
(N) Width over standard bucket	914.0 mm
(O) Turning radius with standard bucket	1557.0 mm
(P) Track, standard tyres	752.0 mm
(Q) Width over standard tyres	901.0 mm

Performance

Tipping load (ISO 14397-1)	686 kg
Rated operating capacity (ISO 14397-1)	344 kg
Lift breakout force	861 daN
Tilt breakout force	867 daN

Cycle Times

Raise lift arms	3.6 s
Lower lift arms	2.7 s
Bucket rollback	1.7 s
Bucket dump	2.1 s

Weights

Operating weight	1268 kg
Shipping weight	1109 kg

Engine

Make / Model	Kubota / D1005-E4B-BC-3
Fuel	Diesel
Cooling	Liquid
Power at 2400 RPM	17.5 kW
Rated speed (EEC 80/1269, ISO 9249)	3000.0 RPM
Torque at 1425 RPM (SAE J1995 Gross)	62.8 Nm
Number of cylinders	3
Displacement	1001 cm ³
Bore	76.0 mm
Stroke	73.6 mm
Lubrication	Gear pump pressure system with filter
Crankcase ventilation	Closed breathing
Air filter	Dry replaceable cartridge with separate safety element
Ignition	Compression (diesel)
Starting aid	Glow plugs

Electrical

Alternator	Belt driven — 65 A — ventilated
Battery	12 V — 600 A cold cranking at -18°C — 115 min reserve capacity
Starter	12 V — gear reduction type — 2.7 kW

Hydraulic System

Pump type	Engine driven, gear type
Pump capacity	37.00 L/min
System relief at quick couplers	207.00 bar
System relief at quick couplers	20.7 MPa
Control valve	Three-spool, open-centre type with float detent on lift and auxiliary spool with detent in one direction (manual)
Hydraulic filter	Full-flow replaceable — 10 µm synthetic media element
Fluid lines	SAE standard tubelines, hoses, and fittings

Hydraulic Cylinders

Lift cylinder (2)	Double-acting
Lift cylinder bore	50.8 mm
Lift cylinder rod	31.8 mm
Lift cylinder stroke	555.8 mm
Tilt cylinder (2)	Double-acting with cushioning feature on dump and rollback
Tilt cylinder bore	76.2 mm
Tilt cylinder rod	31.8 mm
Tilt cylinder stroke	268.2 mm

Drive System

Transmission	Infinitely variable tandem hydrostatic piston pumps, driving two fully reversing hydrostatic motors
Final drive chains	Pre-stressed #60 HS endless roller chain (no master link) and sprockets in sealed chaincase with oil lubrication. (Chains do not require periodic adjustments.) Two chains per side with no idler sprocket.
Main drive	Fully hydrostatic; four-wheel drive
Axle size	38.1 mm, heat treated. Axle tubes welded to chaincase.
Wheel bolts	Five 9/16-inch wheel bolts fixed to axle hubs

Traction

Standard tyres	23 x 5.70-12, 4-ply, Narrow tyres
Max. travel speed (low range)	9.8 km/h

Fluid Capacities

Chaincase reservoir	11.40 L
Cooling system	5.70 L
Engine oil with filter	3.69 L
Fuel tank	24.60 L
Hydraulic reservoir	5.00 L
Hydraulic / Hydrostatic system	15.10 L

Fluid Specifications

Engine coolant

Propylene glycol/water mix (53% - 47%) with freeze protection to -37°C

5 L can - 6904844A, 25 L container - 6904844B, 209 L drum - 6904844C, 1000 L tank - 6904844D

Engine oil

Oil must meet API Service Classification of CD, CE, CF4, CG4, or better. Recommended SAE viscosity number for anticipated temperature range.

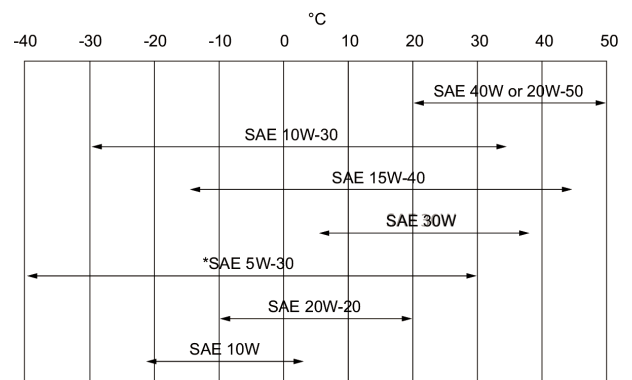

Hydraulic fluid

* Can be used only when available with appropriate diesel rating. For synthetic oil use the recommendation from the oil manufacturer.

Bobcat Superior SH, 5 L can - 6904842A, 25 L container - 6904842B, 209 L drum - 6904842C, 1000 L tank - 6904842D

Bobcat Bio Hydraulic, 5 L can - 6904843A, 25 L container - 6904843B, 209 L drum - 6904843C, 1000 L tank - 6904843D

Motor oil is not an acceptable alternative fluid.

Controls

Engine Starting

Hand lever throttle

Key-type starter switch and shutdown. Automatically activated glow plugs.

Front auxiliary (standard)
 Loader hydraulics tilt and lift
 Service brake

Lateral movement of right-hand steering lever

Separate foot pedals

Secondary brake
 Parking brake
 Vehicle steering
 Auxiliary pressure release

Two independent hydrostatic systems controlled by two hand-operated steering levers

One of the hydrostatic transmissions

Rocker switch on left-hand instrument panel

Direction and speed controlled by two hand levers

Lateral movement of right-hand steering lever after engine has been shut off

Instrumentation

The following loader functions are monitored by a combination of gauges and warning lights in the operator's line of sight. The system alerts the operator of monitored loader malfunctions by way of audible alarm and visual warning lights.

Standard Instrument Panel

- Gauges
 - Hour-meter
 - Engine coolant temperature
 - System voltage
 - Fuel level
- Indicators
 - Bobcat Interlock Control System
 - Seat belt
 - Seat bar
 - Valve (lift and tilt functions)
 - Parking brake
- Warning lights
 - Engine oil pressure
 - Engine coolant temperature
 - Transmission charge pressure
 - Hydraulic filter
 - Hydraulic oil temperature
 - Hydrostatic charge pressure

Deluxe Instrument Panel

Same gauges, warning lights and other features as Standard Instrument Panel, plus:

Serviceability

Access is available to the following through the rear door/tailgate and rear screen:

- Air cleaner
- Alternator
- Battery
- Cooling radiators
- Engine oil and fuel filters
- Engine oil drain and dipstick
- Hydraulic oil fill
- Starter

Axle hubs provide protection for the axle seals

Bob-Tach™ pivots have replaceable wear bushings

Easy access to all grease points

Rod end of the tilt cylinder has a replaceable bushing

Tailgate has an optional lock for vandal-proofing

Tailgate is equipped with door-stop to hold door open while servicing

Tip-up operator cab gives access to certain hydraulic system components

Standard Features

- Automatically activated glow plugs
- Bob-Tach™ frame
- Back-up alarm
- Bobcat Interlock Control System (BICS)
- Front auxiliary hydraulics
- Suspension seat
- Manual
- Lift arm support
- 23 x 5.70-12, 4-ply, Narrow tyres
- Operating lights, front and rear
- Operator cab ¹

- Parking brake
- Rear and top window
- Seat belt
- Seat bar
- Spark arrestor muffler
- CE certification
- Warranty: 24 months or 2000 hours (whichever occurs first)

Options

- Factory Options
 - Deluxe pressurized cab with heating
 - 23 x 8.50-12 6-ply, heavy duty tyres
- Dealer Installed Options
 - 7 and 14-pin electrical attachment control kit
 - Back up alarm kit
 - Cab enclosure kit
 - Fresh air heater kit
 - Catalytic purifier kit
 - Front door kit
 - Engine block heater kit
 - Externally removable rear window
 - Fire extinguisher kit
 - Hydraulic bucket positioning kit
 - Keyless kit
 - Fuel cap locking kit
 - Rear stabiliser kit
 - Rear window wiper kit
 - Replacement operator cab structure
 - Seat belt kit
 - Side windows kit
 - Single-point lift kit
 - Special applications front door kit
 - Tailgate lock kit
 - 4-way flasher / rotating beacon / strobe
 - Water level sensor kit

Attachments

- | | |
|------------------------|---------------------------|
| • Auger Accessories | • Miscellaneous |
| • Augers | • Pallet Fork Accessories |
| • Boring Units | • Pallet Forks, Standard |
| • Breaker Accessories | • Root Grapples |
| • Breakers | • Soil Conditioners |
| • Dozer Blades | • Stump Grinders |
| • Dumping Hoppers | • Sweepers |
| • Grapples, Industrial | • Tillers |
| • Landplanes | • Utility Forks |

1. Roll Over Protective Structure (ROPS) – meets requirements of SAE-J1040 and ISO 3471

Environmental

Operator LpA(98/37 & 474-1)	86 dB(A)
Operator LpA uncertainty	2.5
Noise level LWA(EU Directive 2000/14/EC)	97 dB(A)
Noise level LWA uncertainty	
Whole body vibration (ISO 2631-1)	1.29 ms ⁻²
Whole body vibration uncertainty	
Hand-arm vibration (ISO 5349-1)	1.54 ms ⁻²
Hard-arm vibration uncertainty	