

Flail cutter DK 19 series

Technical specification table :

Oil flow rate requested :	100 l/min
Maximum operating pressure :	250 bar
Engine :	33 cm ³ , bi - directional
External drain :	yes
Self - weight :	700 kg
Working width :	1.900 mm
Dimensions :	

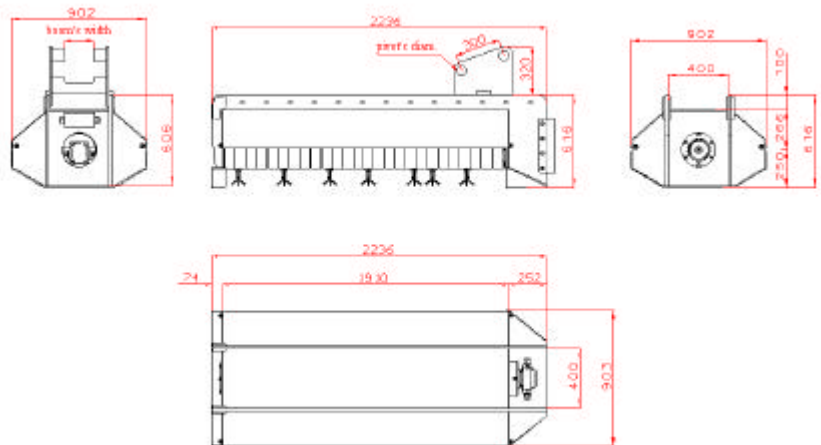

Colour :	RAL 1028
Connection plate VD 02 :	produced with dimensions specified by the customer (boom's width, pivot's diameter) with standard inter axes between holes 300 mm. Weight : 40 kg, possibility of quick coupling system.
Knives :	cut up to 10 cm diameter
Operating weight machine :	14 - 20 T

