

Alldrive 3 tonne Powerswivel

Specifications

Dimensions (mm)	
A	4010
B	1770
C	2013
D	1500
E	1760
F	1930
G	271
H	1600
I	1130
J	1150
K	475
L	3290
M	2460
N	260
P	2964

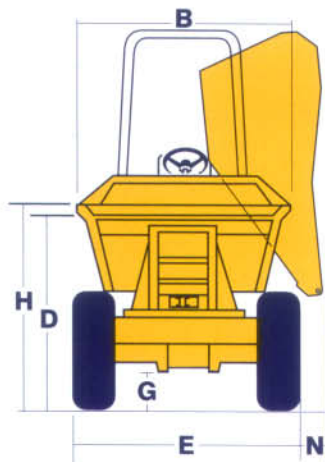
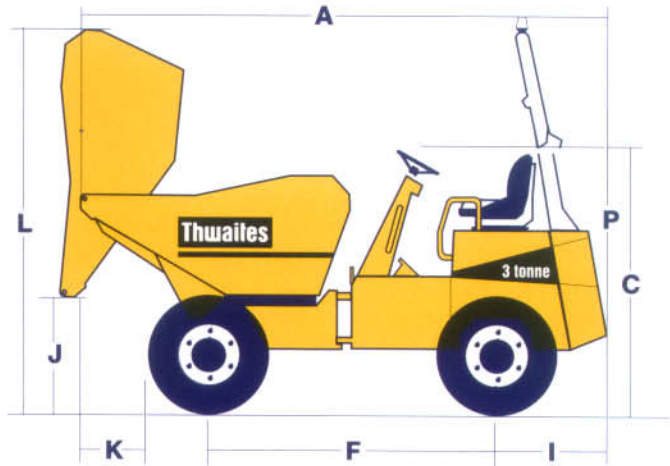

Model	Max. Safe Load Tonnes	Skip				Drive	Transmission	
		Front Tip	Power Swivel	Hi Swivel	Hi Tip		Powershuttle	Powershift
Alldrive 9	9	•				4x4	•	•
Alldrive 7	7	•				4x4	•	•
Alldrive 6	6	•	•			4x4	•	•
Alldrive 5	5	•	•			4x4	•	•
Alldrive 4.5	4.5		•			4x4	Hydrostatic	
Alldrive 4	4	•	•			4x4	Manual	
Alldrive 3.5	3.5		•			4x4	Hydrostatic	
Alldrive 3	3	•	•			4x4	Manual	
Alldrive 2.3	2.3		•	•		4x4	Hydrostatic	
Alldrive 2	2	•	•	•		4x4	Manual	
Slimline	1.5 / 1.75	•	•		•	4x2	Manual	
Nimline Manual Start	1	• Gravity Tip				4x2	Manual	

Alldrive 3 tonne Powerswivel

Specifications

Capacities

Max. safe load	3000 kg
Heaped	1870 litres
Struck	1350 litres
Water	1100 litres

Engine

Yanmar 4TNE84, 41.2 bhp (30.7 kW) at 2800 rpm, 4 cylinder water cooled direct injection diesel. Max torque 126 Nm (93 lbf ft). Electric starting, hour meter, battery isolator switch and heavy duty cyclonic air cleaner positioned within the lockable engine compartment.

Noise Levels

Operator's ear 84 LpA, airborne sound power level 105 LwA (to 86/662/EEC).

Transmission

Heavy duty gearbox, three forward, one reverse, constant mesh change on the move with nickel chrome case hardened gears. Drive through 229 mm (9") dia heavy duty clutch. Transfer reduction box.

Speeds	1	3.9 km/h (2.4 mph)
	2	9.0 km/h (5.6 mph)
	3	16.6 km/h (10.5 mph)
	Reverse	4.4 km/h (2.75 mph)

Tyres	11.5/80 x 15.3
	8 ply
	Track grip tread

Brakes and Axles

Totally enclosed multiplate oil-immersed discs mounted on front axle effective on all four wheels. Automatic adjustment for wear. Hand-operated parking brake. Heavy-duty axles with epicyclic reduction and fully floating halfshafts.

Kinglink Chassis

Front and rear chassis constructed from deep section folded steel plate, with three-point Kinglink giving centre articulation and oscillation for better stability, traction and extra safety on site.

Skips

Hydraulically operated, 5 mm steel base plates, fully welded, mouth and sides of skips reinforced with box sections giving greater strength to minimise skip damage. No material traps. Powerswivel mounted on ball bearing turntable with powered rotation through 180° by means of twin slewing cylinders, operated by a single dual axis control lever. Automatic safety lock holds skip in central position when travelling.

Seating & Controls

Adjustable suspension seat, accessible from both sides. Audible warning device at key start 'on' position. Super bright warning lights for all critical functions Electric horn, hour counter. Large pedal pads with handbrake and hydraulic controls ready to hand. Operators weatherproof instruction book secured by wire cable retainer, housed in special slot within steering leg guard.

Service Access

Lockable 3 sided cover opens to provide easy access from ground level to engine service points, all located on the same side. Rear chassis panel can be hinged back on retainers. Additional service access door incorporates the battery. Moulded diesel and hydraulic tanks positioned low in the chassis side members, permitting access to the filler caps from ground level.

Electrics

Wiring harness contained within conduits and all electrical components water resistant to IP65/67 standards.

Steering & Hydraulics

Hydraulic power steering. Return line filtration for all services and large capacity suction strainer in the tank to give full circuit protection. Hydraulic test point fitted as standard.

Tank capacities	Fuel	45 litres
	Hydraulic	45 litres

Shipping Cube	14,26 m ³
----------------------	----------------------

Unladen Weight	2430 kg
-----------------------	---------

Clearance Diameter	9.3 m
---------------------------	-------

Towing Bracket	Standard
-----------------------	----------

ROPS

For the UK and other markets where it is a legal requirement, a ROPS bar is fitted as standard.

Optional Extras

Folding ROPS frame, ROPS/FOPS frame and canopy. Beacon. Full road lighting equipment. UK road equipment. Anti theft device.

Thwaites



We reserve the right to change all specifications without prior notice. Printed in England 20 September 2001

Thwaites Ltd. Leamington Spa, Warwickshire CV32 7NQ, England
Tel +44 (0)1926 422471 Fax +44 (0)1926 337155
www.thwaitesdumpers.co.uk